

# DESIGN NOTES

## Big Power for Big Processors: The LTC1430 Synchronous Regulator – Design Note 113

Dave Dwellley

Linear Technology introduces the LTC<sup>®</sup>1430 switching regulator controller for high power 5V step-down applications where efficiency, output voltage accuracy and board space requirements are critical. The LTC1430 is designed to be configured as a synchronous buck converter with a minimum of external components. It runs at a fixed switching frequency (nominally 200kHz) and provides all timing and control functions, adjustable current limit and soft start, and level shifted output drivers designed to drive an all N-channel synchronous buck converter architecture. The switch driver outputs are capable of driving multiple, paralleled power MOSFETs with submicrosecond slew rates, providing high efficiency at very high current levels and eliminating the need for a heat sink in most designs.

The LTC1430 is usable in converter designs providing from a few amps to over 50A of output current, allowing it to supply 3.xV power to current hungry arrays of microprocessors. A novel “safety belt” feedback loop provides excellent large-signal transient response with the simplicity of a voltage feedback design. The LTC1430 also includes a micropower shutdown mode that drops the quiescent current to 1 $\mu$ A. An all N-channel synchronous buck architecture allows the use of cost-effective, high power N-channel MOSFETs. The on-chip output drivers feature

separate power supply inputs and internal level shifters allowing the MOSFET gate drive to be tailored for logic level or standard devices. External component count in the high current path is minimized by eliminating low value current sense resistors. Voltage feedback eliminates the need for current sensing under normal operating conditions and output current limit is sensed by monitoring the voltage drop across the  $R_{DS(ON)}$  of M1 during its ON state.

### LTC1430 Performance Features

The LTC1430 uses a voltage feedback loop to control output voltage. It includes two additional internal feedback loops to improve high frequency transient response. A MAX loop responds within a single clock cycle when the output exceeds the set point by more than 3%, forcing the duty cycle to 0% and holding M2 on continuously until the output drops back into the acceptable range. A MIN loop kicks in when the output sags 3% below the set point, forcing the LTC1430 to 90% duty cycle until the output recovers. The 90% maximum ensures that charge pump drive continues to be supplied to the top MOSFET driver, preventing the gate drive to M1 from deteriorating during extended transient loads. The MAX feedback loop is always

LT, LTC and LT are registered trademarks of Linear Technology Corporation.

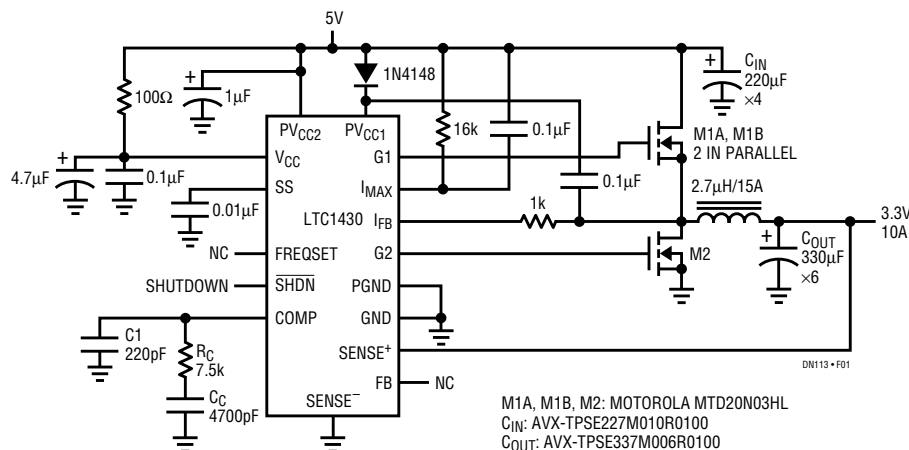

Figure 1. Typical 5V to 3.3V, 10A LTC1430 Application

active, providing a measure of protection even if the 5V input supply is accidentally shorted to the lower microprocessor supply. The MIN loop is disabled at start-up or during current limit to allow soft start to function and to prevent MIN from taking over when the current limit circuit is active.

The LTC1430 includes an onboard reference trimmed to 1.265V  $\pm$ 10mV and an onboard 0.1% resistor divider string that provides a fixed 3.3V output. It specifies load regulation of better than 20mV and line regulation of 5mV, resulting in a total worst-case output error of  $\pm$ 1.7% when used with the internal divider or 0.1% external resistors. The internal reference will drift an additional  $\pm$ 5mV over the 0°C to 70°C temperature range, providing a  $\pm$ 2.1 total error budget over this temperature range.

The LTC1430 includes an internal oscillator that free runs at any frequency between 100kHz and 500kHz. The oscillator runs at a nominal 200kHz frequency with the FREQ pin floating. An external resistor from FREQ to ground will speed up the internal oscillator, whereas a resistor to  $V_{CC}$  will slow the oscillator. The LTC1430 will shut down if the SHDN pin is low continuously for more than 50 $\mu$ s, reducing the supply current to 1 $\mu$ A.

### A Typical 5V to 3.3V Application

The typical application for the LTC1430 is a 5V to 3.3V converter on a PC motherboard. The output is used to power a Pentium® processor and the input is taken from the system 5V  $\pm$ 5% supply. The LTC1430 provides the precisely regulated voltage required without an external precision reference or trimming. Figure 1 shows a typical application with a 3.3V  $\pm$ 1% output voltage and a 12A output current limit. The power MOSFETs are sized so as not to require a heat sink under ambient temperature conditions up to 50°C. Typical efficiency is shown in Figure 2.

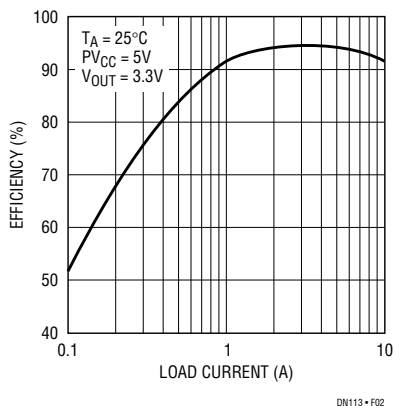
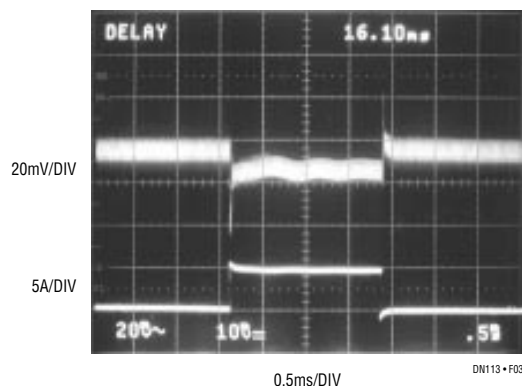

**Figure 2. Figure 1 Circuit Efficiency. Note That Efficiency Peaks at a Respectable 95%**

The 12A current limit is set by the 16k resistor R1 from  $PV_{CC}$  to  $I_{MAX}$  in conjunction with the 0.035 $\Omega$  on resistance of the MOSFETs (M1a, M1b). The 0.1 $\mu$ F capacitor in parallel with R1 improves power supply rejection at  $I_{MAX}$ , providing consistent current limit performance with voltage spikes present at  $PV_{CC}$ .  $C_{SS}$  sets the soft start time; the 0.01 $\mu$ F value shown provides a 3ms start-up time. The 2.7 $\mu$ H, 15A inductor allows the peak current to rise to the full current limit value without saturating the inductor core. This allows the circuit to withstand extended output short circuits. The inductor value is a compromise between peak ripple current and output current slew rate, which affects large-signal transient response. If the output load is expected to generate large output current transients (as large microprocessors tend to do) the inductor value will need to be quite low, in the 1 $\mu$ H to 10 $\mu$ H range.

Loop compensation is critical for obtaining optimum transient response with a voltage feedback system. The compensation components shown here give good response when used with the output capacitor values and brands shown (Figure 3). The output capacitor ESR has a significant effect on the transient response of the system; for best results, use the largest value, lowest ESR capacitors that will fit the budget and space requirements. Several smaller capacitors wired in parallel can help reduce total output capacitor ESR to acceptable levels. Input bypass capacitor ESR is also important to keep input supply variations to a minimum with 10A<sub>P-P</sub> square wave current pulses flowing into M1. AVX TPS series surface mount tantalum capacitors and Sanyo OS-CON organic electrolytic capacitors are recommended for both input and output bypass duty.

Pentium is a registered trademark of Intel Corporation.



**Figure 3. Transient Response: 0A to 5A Load Step Imposed on Figure 1's Output**

For literature on our Switching Regulators, call **1-800-4-LINEAR**. For applications help, call (408) 432-1900, Ext. 361